

DSP9200

Wheel Balancer

HUNTER
Engineering Company

SPECIFICATIONS



DSP9200

Power Requirements	196-256V, 3 amp, 50/60 Hz, 1 ph (Power cable includes: NEMA 20 amp plug, L6-20P)
Air Supply Requirements	n/a
Capacity	
Rim Width	1.5 in to 20 in (38 mm to 508 mm)
Rim Diameter	10 in to 24.5 in (254 mm to 622 mm)
ALU	7.5 in to 38 in (191 mm to 965 mm)
Automatic Inner Dataset® Range	10 in to 28 in (254 mm to 711 mm)
Max. Tire Diameter	38 in (965 mm)
Max. Tire Width	20 in (508 mm)
Max. Tire Weight	150 lbs (68 kg)
Imbalance Resolution	± 0.05 oz (1.0 g)
Placement Accuracy	512 positions, ± 0.35°
Balancing Speed	150 rpm
Motor	Programmable drive system and DC motor
Shipping Weight	475 lbs (215 kg)

MODEL FEATURES / DIMENSIONS

Split Spoke® & Split Weight Modes	Automatic Double Dataset® Arms	Quick-Thread™ Auto-Clamping	Servo Stop Drive Control	Width (W)	Height (H)	Depth (D)
✓	✓	✓	✓	52.5 in (1334 mm)	70.5 in (1785 mm)	55 in (1397 mm)

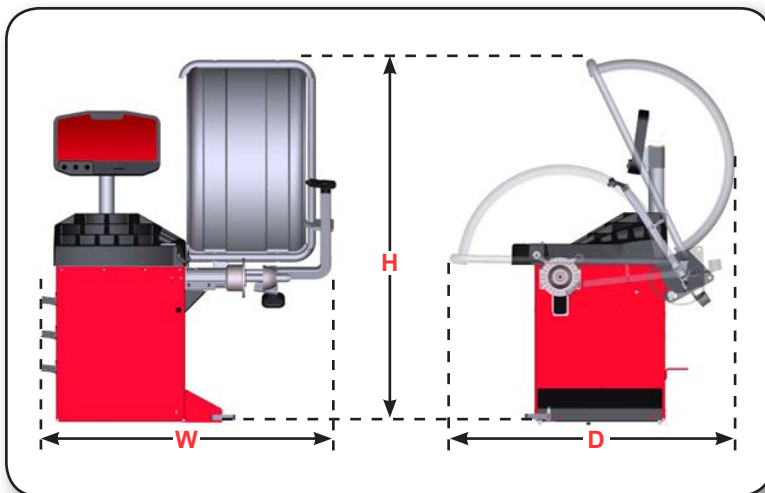

For balancer information visit:
www.hunter.com/balancer

For local contact visit:
www.hunter.com/company/findrep.cfm

For general inquiries visit:
www.hunter.com
or call
800-448-6848

Because of continuing technological advancements, specifications, models and options are subject to change without notice.