

TCX625HD & TCX625PHD

Heavy Duty Tire Changer

HUNTER
Engineering Company

SITE REQUIREMENTS / KEY SPECIFICATIONS

SITE REQUIREMENTS	
Operating Voltage	208-230V, 1 ph, 60Hz, 20A NEMA L6-20P
Shipping Weight	1,168 lbs (530 kg)
Width (W)	86 in. (2,184 mm)
Height (H)	40 - 52 in. (1,016 - 1,321 mm)
Depth (D)	25 - 65 in. (635 - 1,651 mm)

SPECIFICATIONS	
Wheel Assembly	
Max. Diameter	55 in. (1,397 mm)
Max. Width	27 in. (686 mm)
Max. Weight	1,545 lbs. (700 kg)
Min. rim-center hole diameter	3.94 in (100 mm)
Max. rim diameter	14.5 - 24.5 in. (368 - 622 mm)
Match Mounting Capable	Yes
Torque	1,250 ft-lbs. (1,695 N•m)
Rotation Speed	7 rpm CW & CCW

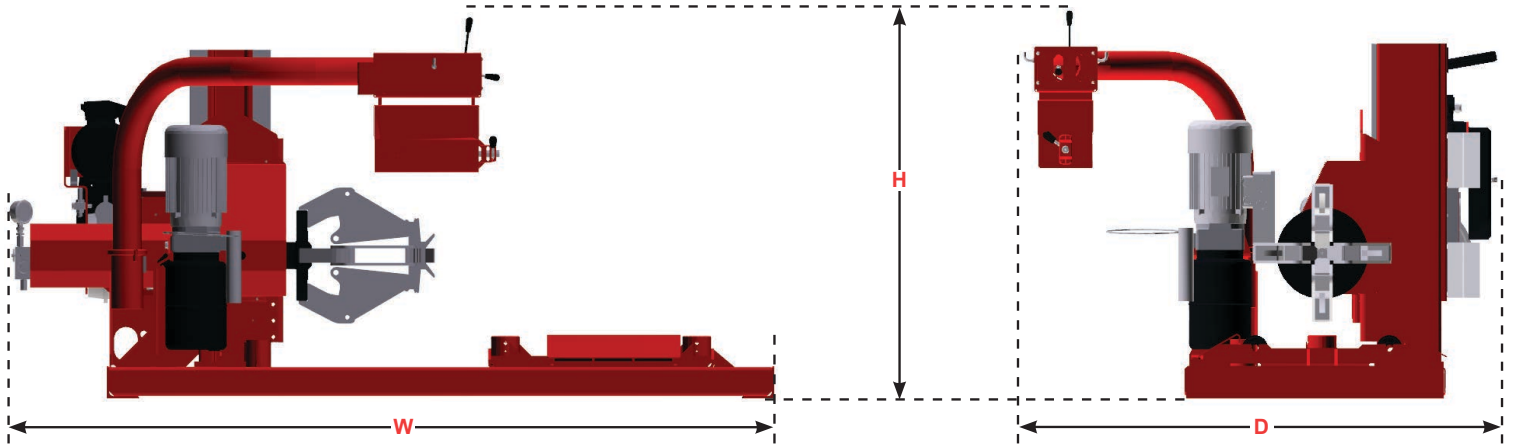

MODEL ACCESSORIES

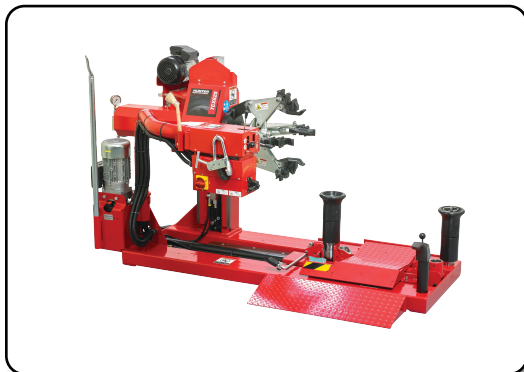

TCX625PHD Shown

ACCESSORIES	TCX625HD	TCX625PHD
Aluminum Wheel Clamp	✓	✓
Steel Wheel Clamp	✓	✓
Tire Paste & Brush	✓	✓
Hook & Hook Pin	✓	✓
Roller	✓	✓
Lever	✓	✓
Two Ramps		✓
Pocket V Cover		✓
Mounting Lever		✓
Aluminum Jaw Covers		✓

For tire changer information visit:
www.hunter.com/tire-changers

For general inquiries visit:
www.hunter.com or call 800-448-6848

For local contact visit:
www.hunter.com/contact-hunter

Because of continuing technological advancements, specifications, models and options are subject to change without notice.

Form 7135-T 03-16b
Copyright © 2016-2019, Hunter Engineering Company