

SITE REQUIREMENTS

TCA34



Shown with optional wheel lift.

TCA28



Shown with optional wheel lift.

	TCA34	TCA28
Power Requirements	208-230V, 15A, 60Hz, 1 ph NEMA 20 amp plug, L6-20P	208-230V, 15A, 60Hz, 1 ph NEMA 20 amp plug, L6-20P
Air Supply Requirements	115-145 psi (8-10 bar)	115-145 psi (8-10 bar)
Shipping Weight	1,039 lbs (471 kg)	849 lbs (294 kg)
Shipping Weight with Wheel Lift	1,128 lbs (511 kg)	915 lbs (415 kg)
Width (W)	43 in. (1,092 mm)	44 in. (1,118 mm)
Height (H)	72 in. (1,829 mm)	71 in. (1,803 mm)
Depth (D)	60 in. (1,524 mm) 78 in. (1,981 mm) with wheel lift	50 in. (1,270 mm)

KEY SPECIFICATIONS

	TCA34	TCA28
Mount / Demount Tool	Polymer Self Inserting Leverless	Polymer Self Inserting Leverless
Clamping Type	Center w/Quick Clamp and Cam Plate	Center w/Quick Clamp and Cam Plate
Bead Loosening Type	Upper / Lower Roller	Rollers or Shovel
Match Mounting Capable	Yes	Yes
Adjustable Clamping Height	Yes	No
Rim Diameter Range	10-30 / 12-32 / 14-34 in.	10-24 / 12-26 / 14-28 in.
Maximum Tire Diameter	50 / 52 / 54 in.	41 / 43 / 45 in.
Maximum Wheel Width	19 in.	15 in.
Drive	Variable up to 14 rpm CW 7 rpm CCW Torque: 867 ft-lbs (1175 Nm)	Variable up to 14 rpm CW 7 rpm CCW Torque: 867 ft-lbs (1175 Nm)

TCA34

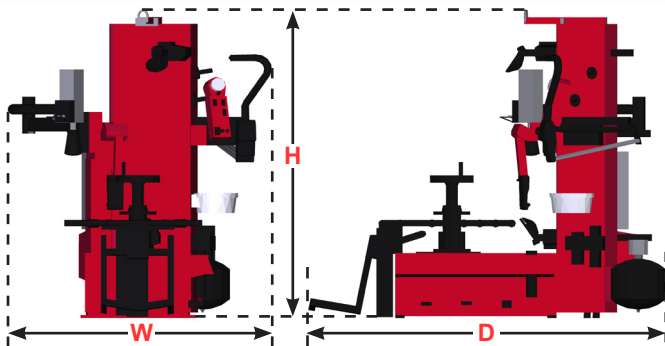

TCA28

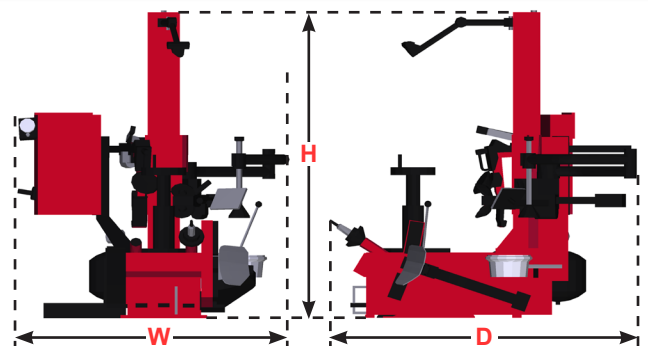

For tire changer information visit:
www.hunter.com/tirechanger

For local contact visit:
www.hunter.com/company/findrep.cfm

For general inquiries visit:
www.hunter.com or call 800-448-6848