

TCX640HD Heavy-Duty Tire Changer

For trucks, tractors & other heavy-duty equipment



Key features at a glance

EXCLUSIVE

Operator-Friendly

- ✓ Mobile pedestal control unit
- ✓ Safe and efficient



Tulip-Style Clamp



- ✓ Two-speed chuck rotation operates clockwise and counter-clockwise
- ✓ Standard clamping capacity of 14-46 in. (356-1168 mm)

STANDARD

Convenient Storage

- ✓ Integrated tool storage on base

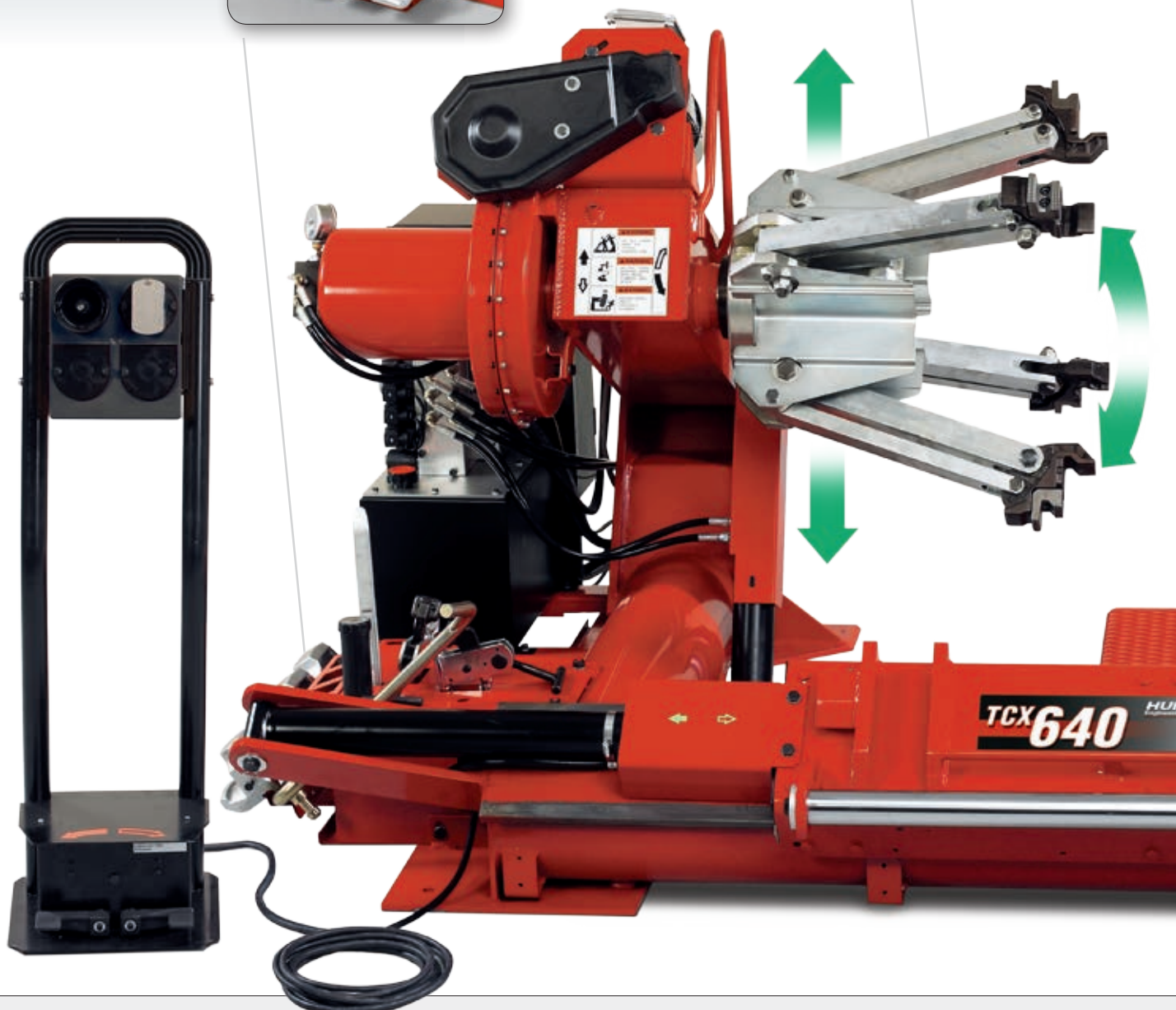

Powerful and Efficient

- ✓ 1600-kg (3527-lb.) capacity spindle head lifts the wheel into position.
- ✓ Power pump runs only when the tire changer is in use

STANDARD

Accessories to Assist

- ✓ Standard disk and hook for mounting and demounting
- ✓ Hydraulic-powered carriage shuttles the wheel toward the clamp



Mount and demount with ease



- ✓ Position the wheel pliers and roll the first bead onto the rim
- ✓ Reposition the pliers and roll the second bead on.
- ✓ Bead loosening and demounting can be as easy as rolling the tire off of the rim in a single step.



The standard hook tool is used to mount and demount tubed and super single tires or more difficult-to-handle wheel assemblies.



Tractor, implement and other specialty wheel assemblies are serviced using the same tools and techniques.

Specifications

Power capacity	
Pump motor	1.5 kW
Gearbox motor (2-speed)	1.3 - 1.8 kW
Min. center hold clamping	3.94 in. (100 mm)
Rim clamping capacity	14-46 in. (356-1168 mm) Up to 56 in. (1422 mm) with optional accessories
Max. wheel assembly...	
Diameter	90.5 in. (2299 mm)
Width	42 in. (1067 mm)
Weight	1588 kg (3,500 lbs.)
Torque	
Low speed	6507 Nm (4,800 ft-lbs.)
High speed	4474 Nm (3,300 ft-lbs.)
Speed	10 rpm and 5 rpm

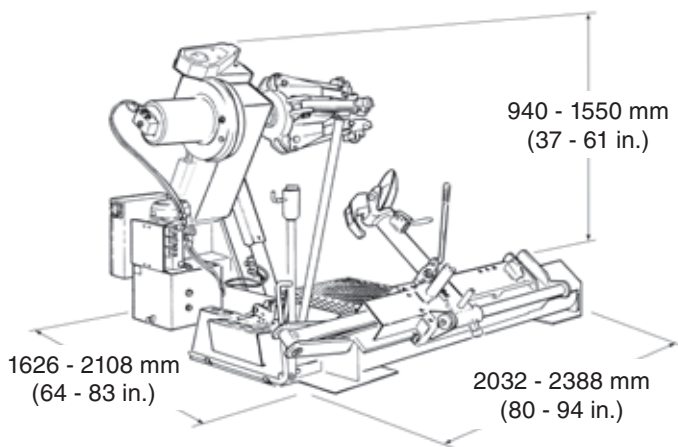

Weight: 740 kg (1631 lbs.)

Models

Heavy-duty tire changer with 2-speed clamp rotation motor.

Part #	Power req.	Hydraulic tool arm position
TCX640-4-3-5	400V-3ph-50hz	
TCX640-4-3-6	400V-3ph-60hz	
TCX640-2-3-5	230V-3ph-50hz	
TCX640-2-3-6	230V-3ph-60hz	
TCX640A-4-3-5	400V-3ph-50hz	✓
TCX640A-4-3-6	400V-3ph-60hz	✓
TCX640A-2-3-5	230V-3ph-50hz	✓
TCX640A-2-3-6	230V-3ph-60hz	✓

Because of continuing technological advancements, specifications, models and options are subject to change without notice.

1215DH

Standard Accessories



- A. Steel wheel pliers (RP11-2005957)
- B. Standard lever (RP11-3006365)
- C. Lubricant and application brush (RP11-8-1140034)
- D. Bead lever (RP11-2105954)

Optional Accessories

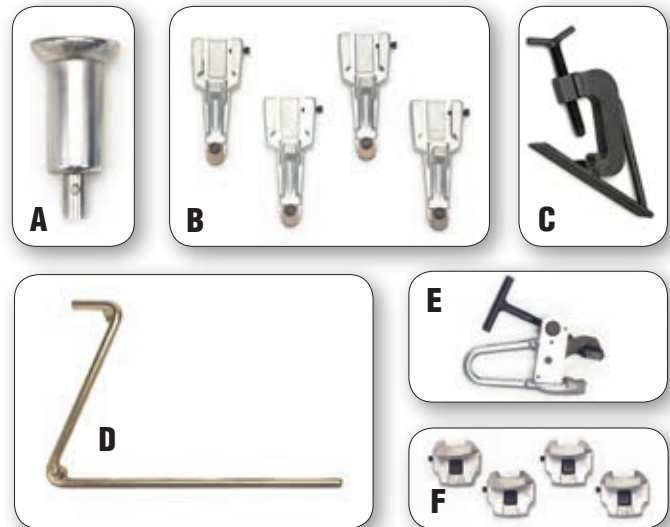

- A. RP11-2306040 - Tubeless roller for easy bead loosening, mounting and demounting of tubeless tires
- B. RP11-8-12100155 - Extensions for self-centering tulip chuck increasing maximum clamping size to 56 in.
- C. RP11-801251904 - Drop-center clamp for skidder and similar type tires
- D. RP11-2105943 - Bead guide bar
- E. RP11-801227195 - Aluminum wheel pliers
- F. RP11-8-12100156 - Alloy wheel clamping jaws

HUNTER
Engineering Company

www.hunter.com

11250 Hunter Drive, Bridgeton, MO 63044 USA
Tel: +1 314-731-3020 Fax: +1 314-731-0132
Email: international@hunter.com